

Energizer®

HYBRID SOLAR FLASHLIGHT

Never get caught in the dark and keep your devices charged with the Energizer Solar Flashlight. Charge the rechargeable battery by USB or solar panel with the flexibility to power your light with back up primary batteries providing light anywhere you need it.

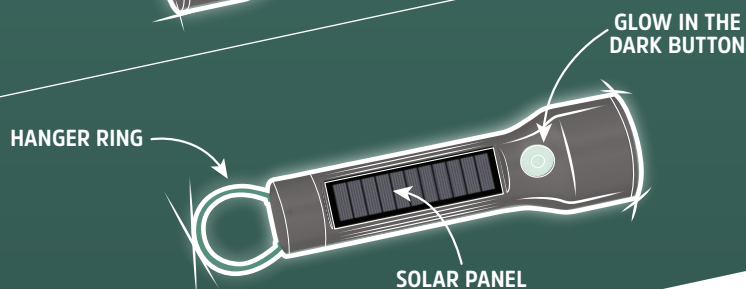
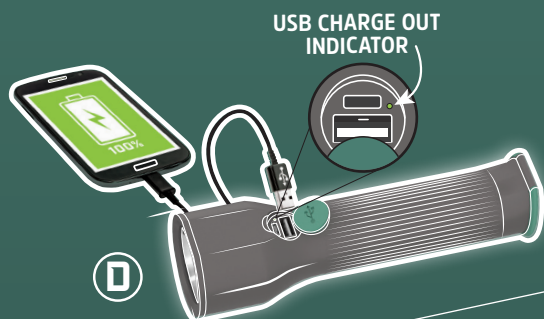
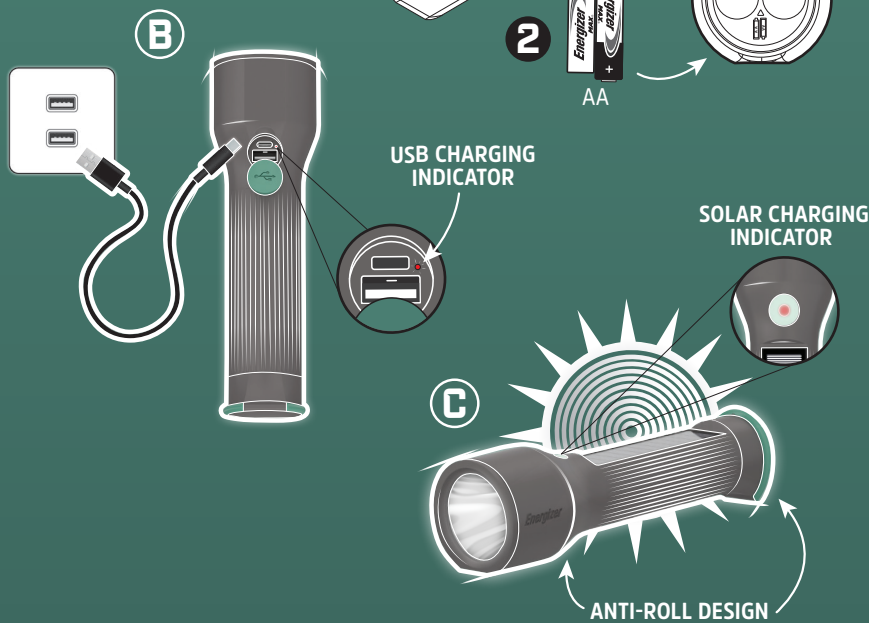
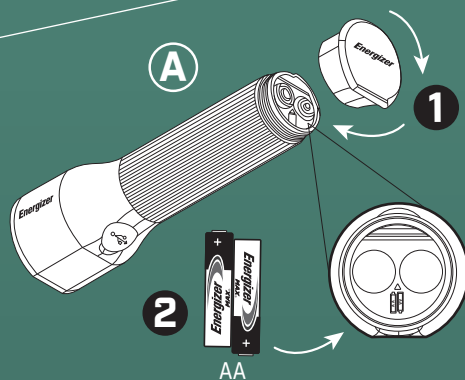
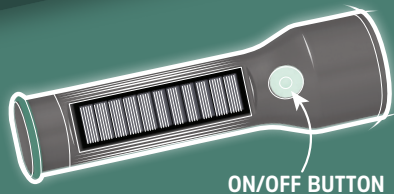

OPERATING INSTRUCTIONS

HOW TO USE:

Press on/off button to turn on.

- Press 1 time for High.
- Press 2 times for Medium.
- Press 3 times for Low.

Press again to turn off.

HOW TO POWER:

A TO REPLACE PRIMARY BATTERIES:

Unscrew tail cap to access primary batteries. Follow diagram on light body for battery orientation.

B RECHARGE VIA USB:

To charge use included USB cord and plug light into any USB charging port. When charging via USB, the red light will flash during charging and will be solid when complete. Rechargeable battery is not user replaceable.

C RECHARGE VIA SOLAR PANEL:

To charge via solar panel, place light in full sun. Anti-roll design helps keep light in an optimal charging position. When charging via the sun, the red charge indicator in the on/off button will flash during charging and will be solid when complete. Full sun is required for fastest charging. Cloudy or indirect sun may charge but it will be slower.

Light may be used while charging, performance may vary.

D TO CHARGE DEVICE:

Plug device cable into charge out port. A charge-out indicating LED is located by the USB port and will illuminate when charging has started. Green light = Charging device

DESIGN FEATURES:

Hanger ring on bottom for storage or handsfree use.

Glow in the dark push button makes your light easy to find!

